

WAN153.00

Lavoce

15" WOOFER

NEODYMIUM MAGNET
ALUMINIUM BASKET DRIVER



- 3 INCH CCAW VOICE COIL
- 98.5 dB/SPL SENSITIVITY
- 1000 WATT PROGRAM POWER HANDLING
- FEM OPTIMIZED MOTOR AND SUSPENSIONS
- OPTIMIZED COOLING SYSTEM
- RESONANCE FREE AND HEAVY DUTY BASKET DESIGN

GENERAL SPECIFICATIONS

Nominal diameter	mm (in.)	380 (15)
Nominal impedance	Ω	8
Minimum impedance	Ω	5,3
Program power (1)	W	1000
AES Power rating (2)	W	500
Sensitivity (3)	dB	98,5
Frequency range	Hz	45 ÷ 3000
Voice coil diameter	mm (in.)	75 (3)
Chassis material	Aluminium	
Magnet material	Neodymium	
Magnet dimensions OD x h	mm (in.)	75 x 10 (2.95 x 0.4)
Coil material	CCA W	
Former material	Glass Fiber	
Cone material	Water Proof Treated Paper	
Surround material	Polycotton	
Xmax (4)	mm (in.)	7 (0.28)
Xmech (5)	mm (in.)	12,7 (0.5)
Gap height	mm (in.)	10,5 (0.41)
Voice coil winding height	mm (in.)	19 (0.75)
Driver displacement volume	l (ft ³)	4,9 (0.17)

SMALL SIGNAL PARAMETERS

DC resistance	Re	Ohm	4,7
Resonance frequency	Fs	Hz	43
Moving mass	Mms	g (oz)	100 (3.53)
Compliance	Cms	mm/N	0,13
Force factor	BxL	N/A	17,3
Mechanical Q-factor	Qms		9,5
Electrical Q-factor	Qes		0,43
Total Q-factor	Qts		0,41
Equivalent air volume	Vas	l (ft ³)	137 (4.84)
Voice coil Inductance	Le	mH	0,75
Diaphragm area	Sd	cm ² (in. ²)	850 (131.7)
Reference efficiency	Eta 0	%	2,4

SHIPPING INFORMATION

Net weight	kg (lb.)	5,8 (12.7)
Multipack size (1)	mm (in.)	452 x 452 x 204 (17.8 x 17.8 x 8)
Multipack weight	kg (lb.)	8 (17.6)

FREQUENCY RESPONSE

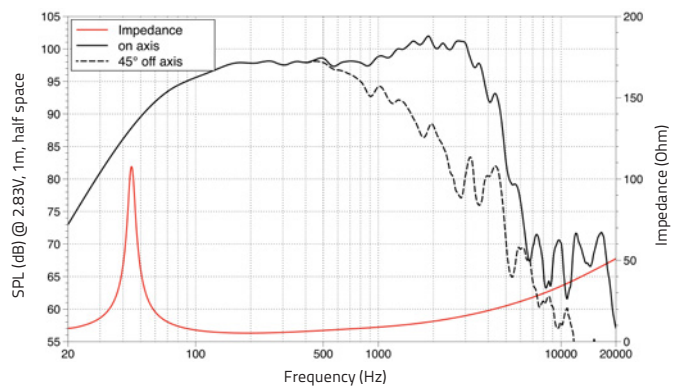

DIMENSIONS mm (in.)

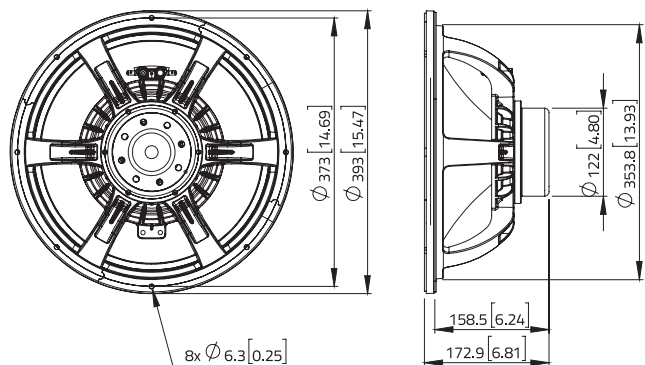

(1) Program power is defined as 3 dB greater than AES Power. (2) Tested for two hours using a continuous, band-limited pink noise signal as per AES 2-1984 Rev. 2003. Loudspeaker tested in free air. (3) From T/S parameters, measured with Klippel DA LPM module. (4) The Xmax is calculated as: $(Hvc - Hg)/2 + Hg/4$. Hvc is the voice coil height and Hg the gap height. (5) The Xmech is calculated as: $(Hvc - Hg)/2 + (Hg - 2)$. Hvc is the voice coil height and Hg the gap height. (6) Thiele-Small parameters are measured after preconditioning: a) at 20°C - 22°C, 50% humidity for 2 hours; b) by Klippel LSI measurement.

All specifications subject to change without notice_B.a

